

Type K01 / K91

DN 10 - 100
PN 63 - 400

Globe / Control Valve

Butt-Welded, Flanged

Data Sheet

Edition: EN 9 / 2015

© MPOWER Engineering, a.s.
Pod vinicí 2028/20, Modřany, 143 00 Praha 4, CZ
T: +420 225 371 300, F: +420 225 371 325
E: info@mpowergroup.eu, W: www.mpowergroup.eu

together we are strong
www.mpowergroup.eu

Content

Application	3
Technical description	3
Testing	3
Operation	3
Installation	3
Connection	3
Materials of main parts	3
Operating data	4
Loss and orifice flow coefficients	6
Dimensions	7
Hand wheel, butt-welded type, DN 10 – 100, PN 100 – 400	7
Hand wheel, flanged type, DN 10 – 100, PN 63 – 400	7
Advantages of construction	10

Copyright

All rights reserved. No content provided herein may be copied, distributed or otherwise reproduced without previous written approval of the company MPOWER Engineering, a.s.

© MPOWER Engineering, a.s., Praha 2015

Contact

MPOWER Engineering, a.s.
Pod viničí 2028 / 20
143 01 Praha 4 – Modřany, CZ

T: +420 225 371 300
F: + 420 225 371 325
E: info@mpowergroup.eu
W: www.mpowergroup.eu



Application

- Shut-off valve K01 or throttling valve K91 with (linear) characteristics
- **Fluids**
Water, steam, gases and other fluids based on material selection
- **Industry**
Power engineering, chemical industry, nuclear power
- **Environments**
Normal, tropical, explosive, seismic

Technical description

- Body is die forging with separate body and cast yoke
- Body seat is hard welded
- Plug with stem and sealing surface of hard weld alloy are integral
- For flanged valves, flanges are welded to the body
- For control valves, the pressure gradient for liquids (i.e. the pressure difference at the inlet and outlet side) is to 5 MPa; expansion ratio (i.e. the ratio of outlet pressure to inlet) for steam and gas is greater or equal to 0.7
- Shut-off valves can be operated in position open – close; throttling valve can be operated also in an intermediate position

Testing

- Valves are pressure tested with water, steam or air for strength and tightness in accordance with working parameters and material according to EN 12266-1
- Min. pressure for the strength testing is 1,5 x PN

Operation

- Hand wheel (with locking device, if required)
- Electric actuator or pneumatic actuator
- Remote control
- Bevel gear

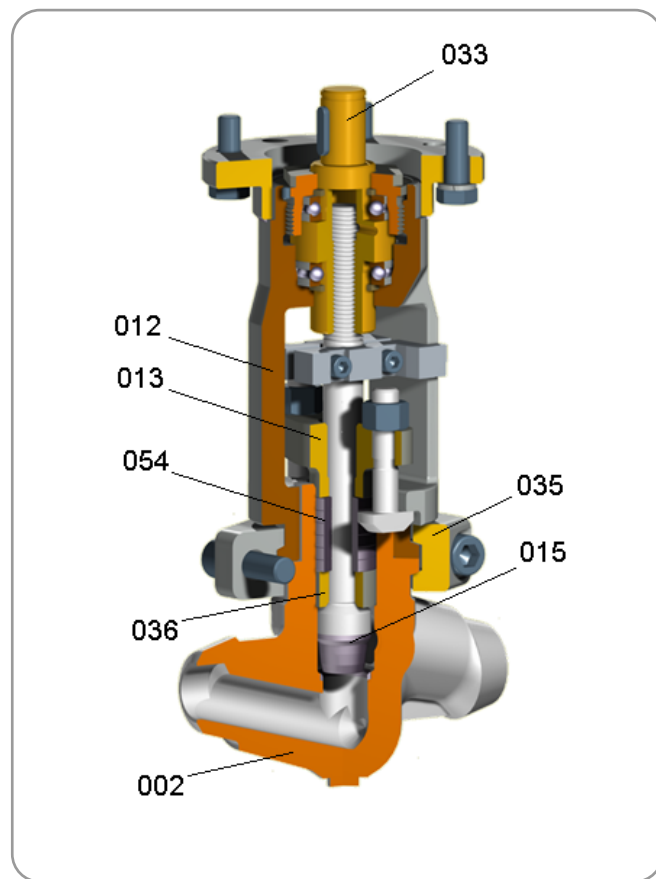

Installation

- Valves may be installed in any position, direction of flow under the plug
- Valves K01 can be installed for flow above the plug, if needed

Connection

- Butt - welded and flanged type according to ČSN, EN, DIN, ANSI, GOST or according to customer request

Materials of main parts

Pos.	Name	Material
002	Body	11 416, P250GH (C22.8), 15 128, 10CrMo9-10, 11CrMo9-10, 13CrMoV4-5, 14MoV6-3, 16Mo3
005	Flange	(15Mo3), X10CrMoVNb9-1, 15NiCuMoNb5-6-4, X6CrNiTi18-10, 08X18H10T
	Seat	Type Stellite 6 (TYP C1111)
013	Bonnet	42 2828 (GS-17CrMoV5 11)
015	Shaft	X22CrMoV12-1, 14X17H2
	Hardfacing	Type Stellite 6 (TYP C1111)
035	Sleeve	42 2828 (GS-17CrMoV5 11)
036	Back seat	X6CrNiTi18-10, 08X18H10T
054	Packing ring	Expanded graphite – density 1,7 g/cm ³
012	Yoke	42 2828 (GS-17CrMoV5 11)
033	Stem nut	423046, CuAl10Fe3Mn2, CuAl10Fe5Ni5-C

Operating data

Material of body	PN	Working pressure MPa / Working temperature °C											
		200	250	300	350	400	450	500	520	540	560	580	600
P250GH (C22.8) (W.Nr. 1.0460)	63	6,3	5,7	4,9	4,2	3,3	2,5	-	-	-	-	-	-
	100	10,0	9,0	7,8	6,7	5,2	4,0	-	-	-	-	-	-
	160	16,0	14,4	12,5	10,7	8,3	6,4	-	-	-	-	-	-
	250	25,0	22,5	19,6	16,7	13,0	10,0	-	-	-	-	-	-
	320	32,0	28,8	25,0	21,3	16,7	12,8	-	-	-	-	-	-
	400	40,0	35,9	31,3	26,7	20,9	16,0	-	-	-	-	-	-
11416	63	6,3	5,9	5,2	4,3	3,8	2,5	-	-	-	-	-	-
	100	10,0	9,4	8,2	6,8	6,0	4,0	-	-	-	-	-	-
	160	16,0	15,0	13,2	10,9	9,6	6,4	-	-	-	-	-	-
	250	25,0	23,5	20,6	17,1	14,9	10,0	-	-	-	-	-	-
	320	32,0	30,1	26,3	21,9	19,1	12,8	-	-	-	-	-	-
	400	40,0	37,6	32,9	27,4	23,9	16,0	-	-	-	-	-	-
15NiCuMoNb5 (W.Nr. 1.6368)	63	6,3	6,3	6,3	6,3	6,3	6,3	-	-	-	-	-	-
	100	10,0	10,0	10,0	10,0	10,0	10,0	-	-	-	-	-	-
	160	16,0	16,0	16,0	16,0	16,0	16,0	-	-	-	-	-	-
	250	25,0	25,0	25,0	25,0	25,0	25,0	-	-	-	-	-	-
	320	32,0	32,0	32,0	32,0	32,0	32,0	-	-	-	-	-	-
	400	40,0	40,0	40,0	40,0	40,0	40,0	-	-	-	-	-	-
16Mo3 (15Mo3) (W.Nr. 1.5415)	63	6,3	6,3	5,5	5,3	5,1	4,9	3,4	2,2	-	-	-	-
	100	10,0	10,0	8,7	8,4	8,1	7,8	5,4	3,4	-	-	-	-
	160	16,0	16,0	13,9	13,4	13,0	12,5	8,6	5,5	-	-	-	-
	250	25,0	25,0	21,7	21,0	20,3	19,6	13,5	8,6	-	-	-	-
	320	32,0	32,0	27,8	26,9	26,0	25,0	17,3	10,9	-	-	-	-
	400	40,0	40,0	34,8	33,6	32,5	31,3	21,6	13,7	-	-	-	-
13CrMo4-5 (W.Nr. 1.7335)	63	6,3	6,3	6,3	6,3	6,0	5,7	5,0	3,4	2,2	1,5	-	-
	100	10,0	10,0	10,0	10,0	9,6	9,0	7,9	5,4	3,5	2,3	-	-
	160	16,0	16,0	16,0	16,0	15,3	14,4	12,7	8,7	5,7	3,7	-	-
	250	25,0	25,0	25,0	25,0	23,9	22,5	19,9	13,6	8,8	5,8	-	-
	320	32,0	32,0	32,0	32,0	30,6	28,8	25,4	17,4	11,3	7,4	-	-
	400	40,0	40,0	40,0	40,0	38,3	35,9	31,8	21,8	14,1	9,3	-	-
11CrMo9-10 (W.Nr. 1.7383)	63	6,3	6,3	6,3	6,3	6,3	6,3	4,9	3,8	2,8	2,1	1,6	1,2
	100	10,0	10,0	10,0	10,0	10,0	10,0	7,8	6,0	4,5	3,4	2,6	2,0
	160	16,0	16,0	16,0	16,0	16,0	16,0	12,5	9,6	7,2	5,4	4,1	3,2
	250	25,0	25,0	25,0	25,0	25,0	25,0	19,6	14,9	11,3	8,4	6,4	4,9
	320	32,0	32,0	32,0	32,0	32,0	32,0	25,0	19,1	14,5	10,8	8,2	6,3
	400	40,0	40,0	40,0	40,0	40,0	40,0	31,3	23,9	18,1	13,4	10,2	7,9
10CrMo9-10 (W.Nr. 1.7380)	63	6,3	6,3	6,3	6,3	6,3	6,0	4,9	3,8	2,8	2,1	1,6	1,2
	100	10,0	10,0	10,0	10,0	10,0	9,6	7,8	6,0	4,5	3,4	2,6	2,0
	160	16,0	16,0	16,0	16,0	16,0	15,3	12,5	9,6	7,2	5,4	4,1	3,2
	250	25,0	25,0	25,0	25,0	25,0	23,9	19,6	14,9	11,3	8,4	6,4	4,9
	320	32,0	32,0	32,0	32,0	32,0	30,6	25,0	19,1	14,5	10,8	8,2	6,3
	400	40,0	40,0	40,0	40,0	40,0	38,3	31,3	23,9	18,1	13,4	10,2	7,9
14MoV6-3 (W.Nr. 1.7715)	63	6,3	6,3	6,3	6,3	6,3	6,3	6,3	5,4	4,1	3,1	-	-
	100	10,0	10,0	10,0	10,0	10,0	10,0	10,0	8,6	6,6	5,0	-	-
	160	16,0	16,0	16,0	16,0	16,0	16,0	16,0	13,8	10,5	8,0	-	-
	250	25,0	25,0	25,0	25,0	25,0	25,0	25,0	21,6	16,4	12,5	-	-
	320	32,0	32,0	32,0	32,0	32,0	32,0	32,0	27,6	21,0	16,0	-	-
	400	40,0	40,0	40,0	40,0	40,0	40,0	40,0	34,6	26,2	19,9	-	-
15128	63	6,3	6,3	6,3	6,3	6,3	6,3	6,2	4,8	3,7	2,8	2,2	1,6
	100	10,0	10,0	10,0	10,0	10,0	10,0	9,8	7,6	5,9	4,5	3,5	2,6
	160	16,0	16,0	16,0	16,0	16,0	16,0	15,7	12,2	9,4	7,2	5,6	4,2
	250	25,0	25,0	25,0	25,0	25,0	25,0	24,5	19,0	14,6	11,3	8,7	6,5
	320	32,0	32,0	32,0	32,0	32,0	32,0	31,4	24,3	18,7	14,5	11,1	8,3
	400	40,0	40,0	40,0	40,0	40,0	40,0	39,2	30,4	23,4	18,1	13,9	10,4

Material of body	PN	Working pressure MPa / Working temperature °C											
		200	250	300	350	400	450	500	520	540	560	580	600
X10CrMoVNb9-1 (W.Nr. 1.4903)	63	6,3	6,3	6,3	6,3	6,3	6,3	6,3	6,3	6,3	5,5	4,4	3,4
	100	10,0	10,0	10,0	10,0	10,0	10,0	10,0	10,0	10,0	8,7	7,0	5,4
	160	16,0	16,0	16,0	16,0	16,0	16,0	16,0	16,0	16,0	13,9	11,1	8,7
	250	25,0	25,0	25,0	25,0	25,0	25,0	25,0	25,0	25,0	21,7	17,4	13,6
	320	32,0	32,0	32,0	32,0	32,0	32,0	32,0	32,0	32,0	27,8	22,3	17,4
	400	40,0	40,0	40,0	40,0	40,0	40,0	40,0	40,0	40,0	34,8	27,8	21,8
X6CrNiTi18-10 (W.Nr. 1.4541)	63	6,1	5,4	5,0	4,7	4,6	4,4	4,3	4,3	4,3	4,3	3,9	3,1
	100	9,7	8,5	7,9	7,5	7,2	7,0	6,9	6,9	6,9	6,8	6,2	5,0
	160	15,5	13,6	12,6	12,1	11,6	11,2	11,0	11,0	11,0	10,9	9,9	8,0
	250	24,2	21,3	19,7	18,8	18,1	17,5	17,2	17,2	17,1	17,1	15,5	12,5
	320	31,0	27,3	25,2	24,1	23,2	22,4	22,1	22,1	21,9	21,9	19,8	16,0
	400	38,7	34,1	31,5	30,1	29,0	28,1	27,6	27,5	27,4	27,4	24,8	19,9
08X18H10T	63	6,0	5,6	5,4	5,0	4,8	4,5	4,1	3,8	3,5	3,1	2,8	2,5
	100	9,5	8,8	8,5	7,9	7,7	7,1	6,6	6,0	5,5	5,0	4,5	4,0
	160	15,2	14,1	13,6	12,7	12,2	11,4	10,5	9,6	8,8	8,0	7,2	6,5
	250	23,8	22,0	21,3	19,9	19,1	17,8	16,4	15,0	13,7	12,5	11,3	10,1
	320	30,4	28,2	27,3	25,4	24,5	22,8	21,0	19,3	17,5	15,9	14,4	12,9
	400	38,0	35,2	34,1	31,8	30,6	28,5	26,2	24,1	21,9	19,9	18,1	16,2

Loss and orifice flow coefficients

Loss coefficients ξ of shut-off valves and orifice flow coefficients K_v of control valves and direction of flow under the plug:

DN		Dimensions		Loss coefficients of shut-off valves ξ	Orifice flow coefficients K_v of control valves $m^3 \cdot hod^{-1}$
mm	"	d	dp		
10, 15	3/8	10,5	12	6,43	2,33
	1/2				
	3/4	13,5	17	10,97	3,25
	1				
20, 25	3/4	19	21	6,88	5,36
	1				
	1 ¹ / ₄	22	28	10,13	6,98
	1 ¹ / ₂				
32, 40	1 ¹ / ₄	28	31	7,17	10,92
	1 ¹ / ₂				
	2	32	39	9,90	11,21
50	1 ¹ / ₂	35	39	7,12	15,27
	2				
	2 ¹ / ₂	43	49	12,14	19,37
80, 100/80	1/4	35	39	7,12	15,27
	3				
	4	43	49	12,14	19,37

Dimensions

Hand wheel, butt-welded type, DN 10 – 100, PN 100 – 400

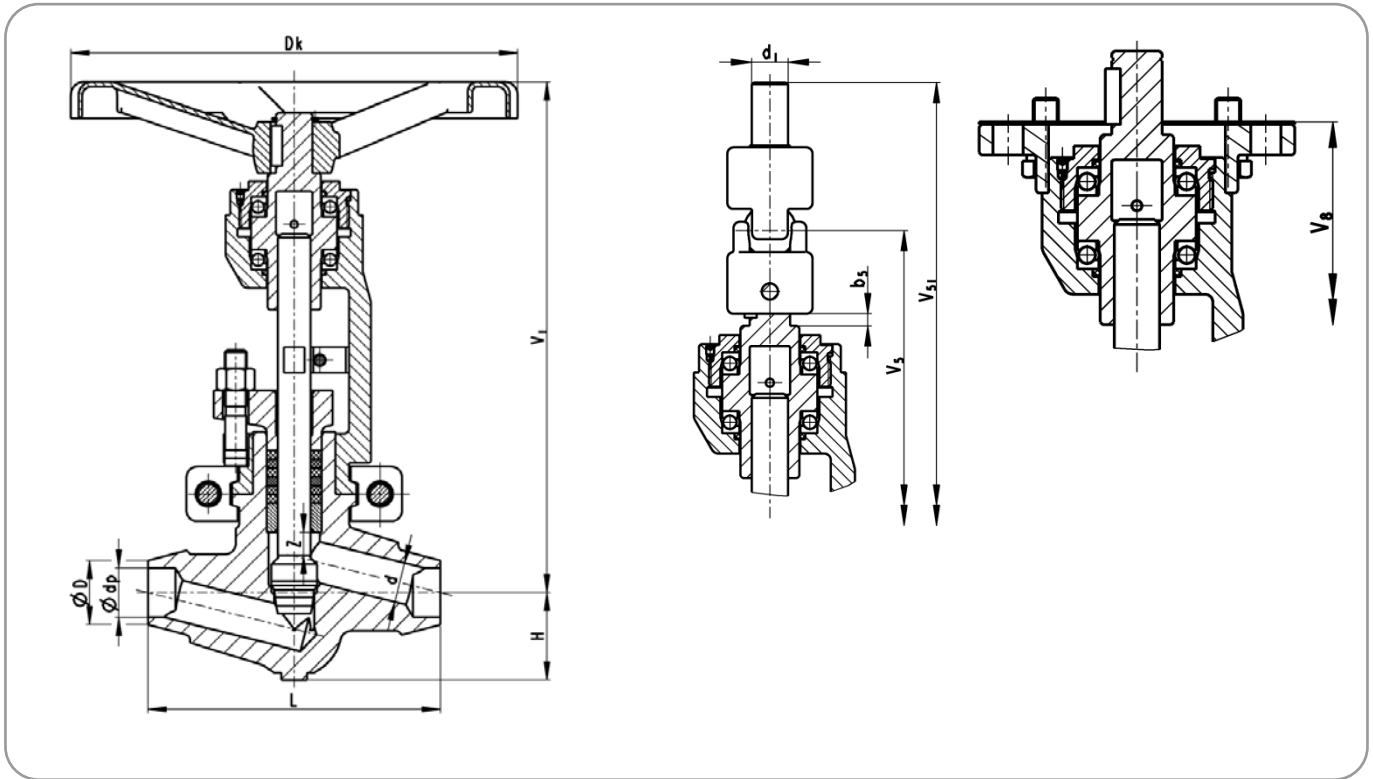

Hand wheel, flanged type, DN 10 – 100, PN 63 – 400

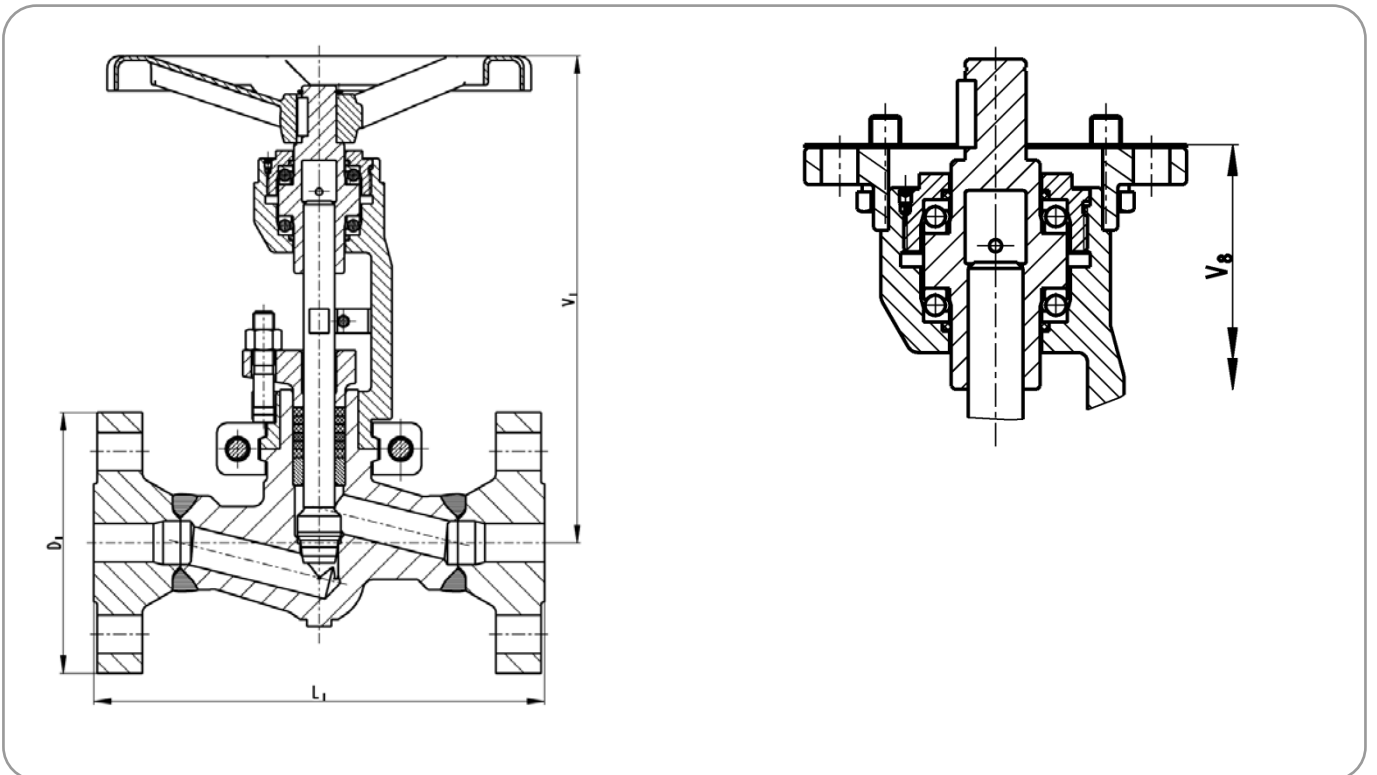

DN	PN	D mm	dp mm	L mm	Z mm	H mm	Hand wheel			Operation by ISO 5210			Remote control				
							D _k mm	V ₁ mm	m kg	OVL.	V ₈ mm	m kg	d ₁ mm	V ₅ mm	V ₅₁ mm	b ₅ mm	m kg
10	100	14	10	150	12	34	200	234	5,2	F10/E	193	6	18	236	309	6	5,7
	160		10														
	250		9														
	320		8														
	400		7														
15	100	22	17	150	12	34	200	234	5,2	F10/E	193	6	18	236	309	6	5,7
	160		16														
	250		15														
	320		15														
	400	27	17														
20	100	27	23	160	16	48	250	280	8,6	F10/E	235	9	18	281	354	10	8,9
	160		21														
	250	30	20														
	320		18														
	400		17														
25	100	35	28	160	16	48	250	280	8,6	F10/E	235	9	18	281	354	10	8,9
	160		26														
	250		24														
	320		24														
	400	43	28														
32	100	43	36	210	20	66	400	376	20	F10/E F14/E	356 314	27 20	29	379	484	1,5	19,6
	160		34														
	250		31														
	320		28														
	400		27														
40	100	49	41	210	20	66	400	376	21,1	F10/E F14/E	356 314	27 20	29	379	484	1,5	19,6
	160		39														
	250		36														
	320		35														
	400	61	39														
50	100	61	52	250	36	83	500	450	33,2	F10/E F14/E	429 384	40 32	29	451	556	6	31,2
	160		49														
	250	64	45														
	320		45														
	400		77														
65/50	100	77	66	250	36	83	500	450	33,2	F10/E F14/E	429 384	40 32	29	451	556	6	31,2
	160		62														
	250		56														
	320		52														
	400		48														
80 100/80	100	*	*	*	*	*	*	*	*	*	*	*	*	*	*	*	*
	160																
	250																
	320																
	400																

Notes: Dimensions of butt-welded type are by ČSN EN 131075, in case of requirement of another standard (EN, DIN, ANSI, GOST) the dimensions could be different.

*) Nominal values on customer request.

DN	PN	D ₁ mm	L1 mm	V ₁ mm		V ₈ mm		m kg	
				Hand wheel	ISO 5210	Hand wheel	ISO 5210	Hand wheel	ISO 5210
10	63-160	100	210	234	193	7,4	8,2	9,5	10,3
	250	125	230						
	320	125	230						
	400	125	260						
15	63-160	105	210	234	193	7,6	8,4	10,2	11
	250	130	230						
	320	130	230						
	400	145	260						
20	63-100	130	230	280	235	12,6	13		
25	63-160	140	230	280	235	13,9	14,3	15,8	16,2
	250	150	260						
	320	160	260						
	400	180	300						
32	63-100	155	260	376	F10/E - 356	26,4	33,4		
40	63-100	170	260	376	F10/E - 356 (F14/E - 314)	28,1	35,1 (28,1)	28,8	35,8 (28,8)
	160	170	260						
	250	185	300						
	320	195	300						
	400	220	350						
50	63	180	300	450	F10/E - 429 (F14/E - 384)	42,3	49,1 (41,1)	43,8	50,6 (42,6)
	100	195	300						
	160	195	300						
	250	200	350						
	320	210	350						
	400	235	400						
65/50	63	205	340	450	F10/E - 429 (F14/E - 384)	44,4	51,2 (43,2)	46,9	53,7 (45,7)
	100	220	340						
	160	220	340						
	250	230	400						
	320	255	400						
	400	290	450						
80 100/80	63	*	*	*	*	*	*	*	*
	100								
	160								
	250								
	320								

Notes: Dimensions of flanged type are by ČSN EN 1092-1, in case of requirement of another standard (EN, DIN, GOST) the dimensions could be different

*) Nominal values on customer request

Advantages of construction

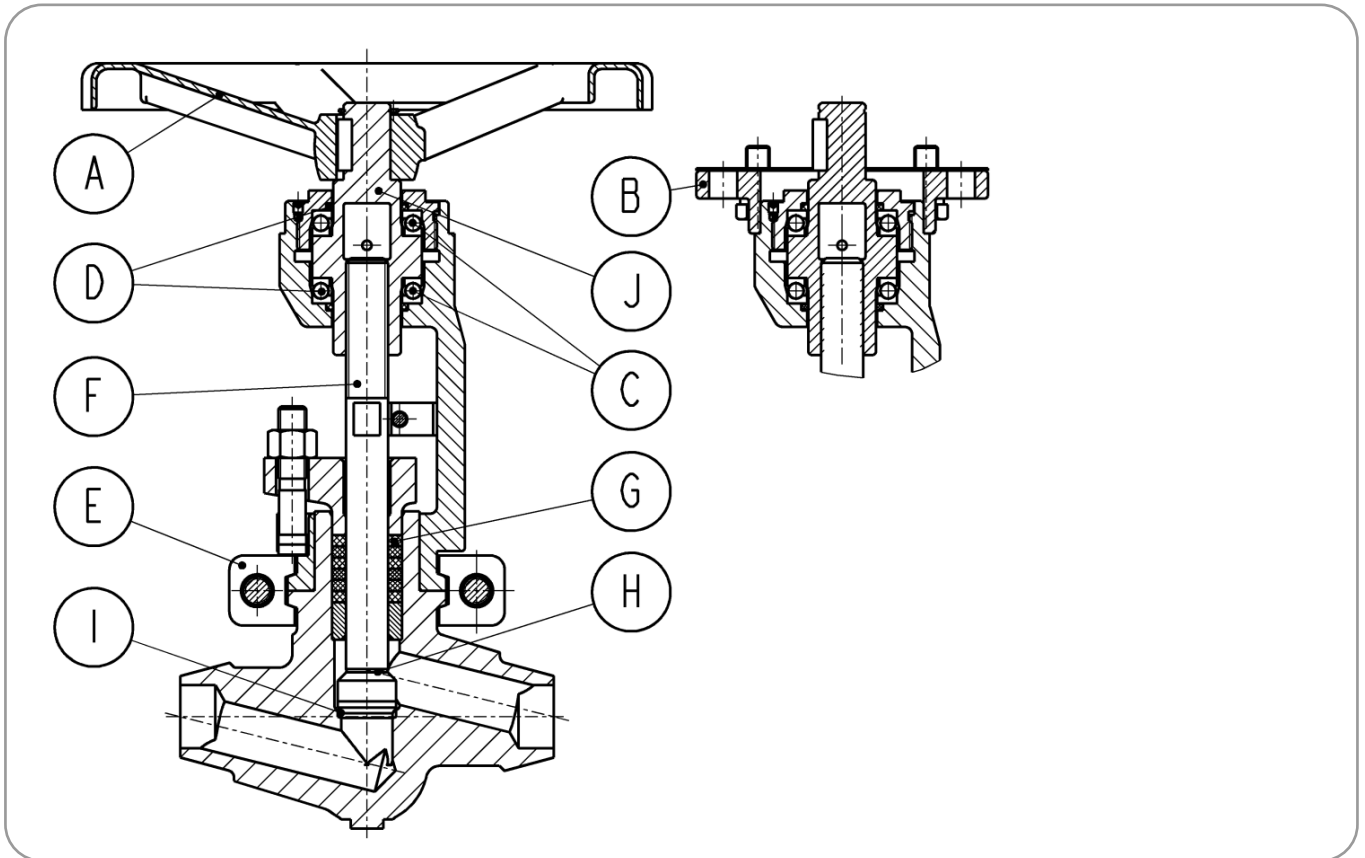

A	Non-rising hand wheel: Advantage in case of lack of space
B	Identical connection for actuators and gears according to ISO 5210: Possibility to use control elements of different producers
C	Stem nut placed in two rolling bearings: Facilitate the operation
D	Dust rings: Protected space of the bearings against dirt
E	Socket of the connection „body – yoke“: Enables fast mounting and dismounting
F	Shaft rising, non-turning: Reliable sealing of shaft in gland
G	Stem gland packing, expanded graphite: Reliable sealing, ecology
H	Shaft with plug made of one piece: Enables dismounting of yoke, incl. gland
I	Sealing surfaces hardfaced: Long-term life time, resistance against wearing-out
J	Stem nut in one design: Enables the change of operation type without dismounting of stem nut

MYYNTI / SALES:

**FINKOVA OY
SINIKELLONTIE 10 B
FI-01300 VANTAA**

TEL: +358 10 229 1570

EMAIL: finkova@finkova.fi

WWW: www.finkova.fi



HUOLTO / SERVICE:

**FINKOVA SERVICE OY
RAUDOITAJANTIE 7 A
FI-06450 PORVOO**

TEL: +358 10 229 1570

EMAIL: info@finkovaservice.fi

WWW: www.finkovaservice.fi

