

Typ K09 / K99

DN 10 - 100
PN 63 - 400

Check Valve

Butt-Welded, Flanged

Data Sheet

Edition: EN 9 / 2015

© MPOWER Engineering, a.s.
Pod vinicí 2028/20, Modřany, 143 00 Praha 4, CZ
T: +420 225 371 300, F: +420 225 371 325
E: info@mpowergroup.eu, W: www.mpowergroup.eu

together we are strong
www.mpowergroup.eu

Content

Application3

Technical description3

Testing3

Installation.....3

Operation.....3

Connection.....3

Materials of main parts3

Operating data4

Loss and flow coefficients5

Dimensions6

 Butt-welded type, DN 10 – 100/80, PN 100 – 400 7

 Flanged type, DN 10 – 100/80, PN 63 – 400 8

Advantages of construction.....9

Copyright

All rights reserved. No content provided herein may be copied, distributed or otherwise reproduced without previous written approval of the company MPOWER Engineering, a.s.

© MPOWER Engineering, a.s., Praha 2015

Contact

MPOWER Engineering, a.s.
 Pod vinicí 2028 / 20
 143 00 Praha 4 – Modřany, CZ

T: +420 225 371 300
 F: + 420 225 371 325
 E: info@mpowergroup.eu
 W: www.mpowergroup.eu



Application

- Self-acting valve, used to stop reverse flow of the fluids
- **Fluids**
Water, steam, gases and other fluids
- **Industry**
Conventional and nuclear energy, chemical industry
- **Environments**
Normal, tropical, explosive, seismic

Technical description

- Body is die forging, screwed cover
- Seats are hardfaced (Stellite)
- Sealing ring is made from expanded graphite
- Flanges are welded to the body

Testing

- Valves are pressure tested with water, steam or air for strength and tightness in accordance with working parameters and material according to EN 12266 – 1
- Minimum pressure for the strength testing is 1,5 x PN

Installation

- Valves K09 can be installed in horizontal position
- Valves K99 can be installed in each position because of the spring
- Direction of flow is under the disc

Operation

- Self-acting

Connection

- Butt-welded or flanged type according to ČSN, EN, DIN, ANSI, GOST or according to customer request

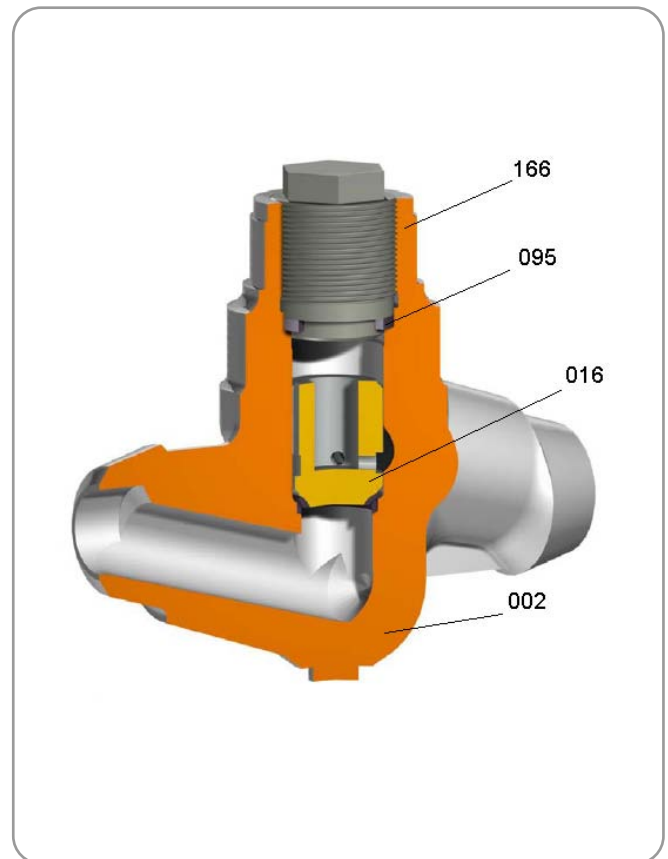

Materials of main parts

Pos.	Name	Material
002	Body	11 416, P250GH (C22.8), 15 128, 10CrMo9-10, 11CrMo9-10, 13CrMoV4-5,
005	Flange	14MoV6-3, 16Mo3 (15Mo3), X10CrMoVNb9-1, 15NiCuMoNb5-6-4, X6CrNiTi18-10, 08X18H10T
	Body hardfacing	Typ Stellite 6 (TYP C1111)
016	Plug	X6CrNiTi18-10, 08X18H10T , 14X17H2
	Plug hardface	Typ Stellite 6 (TYP C1111)
	Spring	NiCr15Fe7TiAl
095	Bonnet gasket	Expandovaný grafit – hustota 1,7 g/cm ³
166	Šroubení	X22CrMoV12-1

Operating data

Material of body	PN	Working pressure MPa / Working temperature °C											
		200	250	300	350	400	450	500	520	540	560	580	600
P250GH (C22.8) (W.Nr. 1.0460)	63	6,3	5,7	4,9	4,2	3,3	2,5	-	-	-	-	-	-
	100	10,0	9,0	7,8	6,7	5,2	4,0	-	-	-	-	-	-
	160	16,0	14,4	12,5	10,7	8,3	6,4	-	-	-	-	-	-
	250	25,0	22,5	19,6	16,7	13,0	10,0	-	-	-	-	-	-
	320	32,0	28,8	25,0	21,3	16,7	12,8	-	-	-	-	-	-
11416	63	6,3	5,9	5,2	4,3	3,8	2,5	-	-	-	-	-	-
	100	10,0	9,4	8,2	6,8	6,0	4,0	-	-	-	-	-	-
	160	16,0	15,0	13,2	10,9	9,6	6,4	-	-	-	-	-	-
	250	25,0	23,5	20,6	17,1	14,9	10,0	-	-	-	-	-	-
	320	32,0	30,1	26,3	21,9	19,1	12,8	-	-	-	-	-	-
15NiCuMoNb5 (W.Nr. 1.6368)	63	6,3	6,3	6,3	6,3	6,3	6,3	-	-	-	-	-	-
	100	10,0	10,0	10,0	10,0	10,0	10,0	-	-	-	-	-	-
	160	16,0	16,0	16,0	16,0	16,0	16,0	-	-	-	-	-	-
	250	25,0	25,0	25,0	25,0	25,0	25,0	-	-	-	-	-	-
	320	32,0	32,0	32,0	32,0	32,0	32,0	-	-	-	-	-	-
16Mo3 (15Mo3) (W.Nr. 1.5415)	63	6,3	6,3	5,5	5,3	5,1	4,9	3,4	2,2	-	-	-	-
	100	10,0	10,0	8,7	8,4	8,1	7,8	5,4	3,4	-	-	-	-
	160	16,0	16,0	13,9	13,4	13,0	12,5	8,6	5,5	-	-	-	-
	250	25,0	25,0	21,7	21,0	20,3	19,6	13,5	8,6	-	-	-	-
	320	32,0	32,0	27,8	26,9	26,0	25,0	17,3	10,9	-	-	-	-
13CrMo4-5 (W.Nr. 1.7335)	63	6,3	6,3	6,3	6,3	6,0	5,7	5,0	3,4	2,2	1,5	-	-
	100	10,0	10,0	10,0	10,0	9,6	9,0	7,9	5,4	3,5	2,3	-	-
	160	16,0	16,0	16,0	16,0	15,3	14,4	12,7	8,7	5,7	3,7	-	-
	250	25,0	25,0	25,0	25,0	23,9	22,5	19,9	13,6	8,8	5,8	-	-
	320	32,0	32,0	32,0	32,0	30,6	28,8	25,4	17,4	11,3	7,4	-	-
11CrMo9-10 (W.Nr. 1.7383)	63	6,3	6,3	6,3	6,3	6,3	6,3	4,9	3,8	2,8	2,1	1,6	1,2
	100	10,0	10,0	10,0	10,0	10,0	10,0	7,8	6,0	4,5	3,4	2,6	2,0
	160	16,0	16,0	16,0	16,0	16,0	16,0	12,5	9,6	7,2	5,4	4,1	3,2
	250	25,0	25,0	25,0	25,0	25,0	25,0	19,6	14,9	11,3	8,4	6,4	4,9
	320	32,0	32,0	32,0	32,0	32,0	32,0	25,0	19,1	14,5	10,8	8,2	6,3
10CrMo9-10 (W.Nr. 1.7380)	63	6,3	6,3	6,3	6,3	6,3	6,0	4,9	3,8	2,8	2,1	1,6	1,2
	100	10,0	10,0	10,0	10,0	10,0	9,6	7,8	6,0	4,5	3,4	2,6	2,0
	160	16,0	16,0	16,0	16,0	16,0	15,3	12,5	9,6	7,2	5,4	4,1	3,2
	250	25,0	25,0	25,0	25,0	25,0	23,9	19,6	14,9	11,3	8,4	6,4	4,9
	320	32,0	32,0	32,0	32,0	32,0	30,6	25,0	19,1	14,5	10,8	8,2	6,3
14MoV6-3 (W.Nr. 1.7715)	63	6,3	6,3	6,3	6,3	6,3	6,3	6,3	5,4	4,1	3,1	-	-
	100	10,0	10,0	10,0	10,0	10,0	10,0	10,0	8,6	6,6	5,0	-	-
	160	16,0	16,0	16,0	16,0	16,0	16,0	16,0	13,8	10,5	8,0	-	-
	250	25,0	25,0	25,0	25,0	25,0	25,0	25,0	21,6	16,4	12,5	-	-
	320	32,0	32,0	32,0	32,0	32,0	32,0	32,0	27,6	21,0	16,0	-	-
15128	63	6,3	6,3	6,3	6,3	6,3	6,3	6,2	4,8	3,7	2,8	2,2	1,6
	100	10,0	10,0	10,0	10,0	10,0	10,0	9,8	7,6	5,9	4,5	3,5	2,6
	160	16,0	16,0	16,0	16,0	16,0	16,0	15,7	12,2	9,4	7,2	5,6	4,2
	250	25,0	25,0	25,0	25,0	25,0	25,0	24,5	19,0	14,6	11,3	8,7	6,5
	320	32,0	32,0	32,0	32,0	32,0	32,0	31,4	24,3	18,7	14,5	11,1	8,3
	400	40,0	40,0	40,0	40,0	40,0	40,0	39,2	30,4	23,4	18,1	13,9	10,4

Material of body	PN	Working pressure MPa / Working temperature °C											
		200	250	300	350	400	450	500	520	540	560	580	600
X10CrMoVNb9-1 (W.Nr. 1.4903)	63	6,3	6,3	6,3	6,3	6,3	6,3	6,3	6,3	6,3	5,5	4,4	3,4
	100	10,0	10,0	10,0	10,0	10,0	10,0	10,0	10,0	10,0	8,7	7,0	5,4
	160	16,0	16,0	16,0	16,0	16,0	16,0	16,0	16,0	16,0	13,9	11,1	8,7
	250	25,0	25,0	25,0	25,0	25,0	25,0	25,0	25,0	25,0	21,7	17,4	13,6
	320	32,0	32,0	32,0	32,0	32,0	32,0	32,0	32,0	32,0	27,8	22,3	17,4
	400	40,0	40,0	40,0	40,0	40,0	40,0	40,0	40,0	40,0	34,8	27,8	21,8
X6CrNiTi18-10 (W.Nr. 1.4541)	63	6,1	5,4	5,0	4,7	4,6	4,4	4,3	4,3	4,3	4,3	3,9	3,1
	100	9,7	8,5	7,9	7,5	7,2	7,0	6,9	6,9	6,9	6,8	6,2	5,0
	160	15,5	13,6	12,6	12,1	11,6	11,2	11,0	11,0	11,0	10,9	9,9	8,0
	250	24,2	21,3	19,7	18,8	18,1	17,5	17,2	17,2	17,1	17,1	15,5	12,5
	320	31,0	27,3	25,2	24,1	23,2	22,4	22,1	22,1	21,9	21,9	19,8	16,0
	400	38,7	34,1	31,5	30,1	29,0	28,1	27,6	27,5	27,4	27,4	24,8	19,9
08X18H10T	63	6,0	5,6	5,4	5,0	4,8	4,5	4,1	3,8	3,5	3,1	2,8	2,5
	100	9,5	8,8	8,5	7,9	7,7	7,1	6,6	6,0	5,5	5,0	4,5	4,0
	160	15,2	14,1	13,6	12,7	12,2	11,4	10,5	9,6	8,8	8,0	7,2	6,5
	250	23,8	22,0	21,3	19,9	19,1	17,8	16,4	15,0	13,7	12,5	11,3	10,1
	320	30,4	28,2	27,3	25,4	24,5	22,8	21,0	19,3	17,5	15,9	14,4	12,9
	400	38,0	35,2	34,1	31,8	30,6	28,5	26,2	24,1	21,9	19,9	18,1	16,2

Loss and flow coefficients

Loss coefficients ξ of the check shut-off valves:

DN		Dimensions		Los coefficients of the check shut-off valves ξ
mm	"	d	dp	
10, 15	3/8	10,5	12	9,07
	1/2			
	3/4	13,5	17	
	1			
20, 25	3/4	19	21	9,86
	1			
	1 ¹ / ₄	22	28	
	1 ¹ / ₂			
32, 40	1 ¹ / ₄	28	31	8,3
	1 ¹ / ₂			
	2	32	39	
	2			
50, 65/50	1 ¹ / ₂	35	39	7,79
	2			
	2 ¹ / ₂	43	49	
	2 ¹ / ₂			
80, 100/80	1/4	35	39	7,79
	3			
	4	43	49	
	4			

Dimensions

Butt-welded type, DN 10 – 100/80, PN 100 – 400

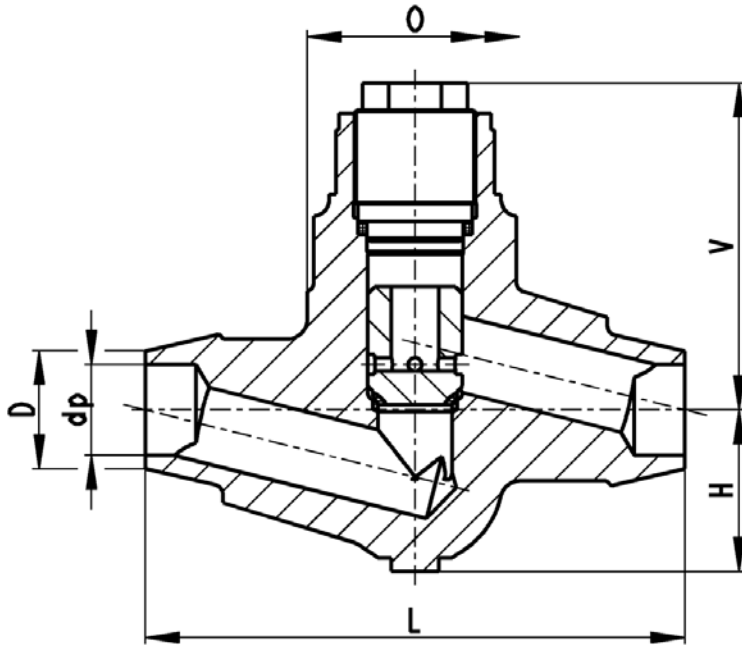

Flanged type, DN 10 – 100/80, PN 63 – 400

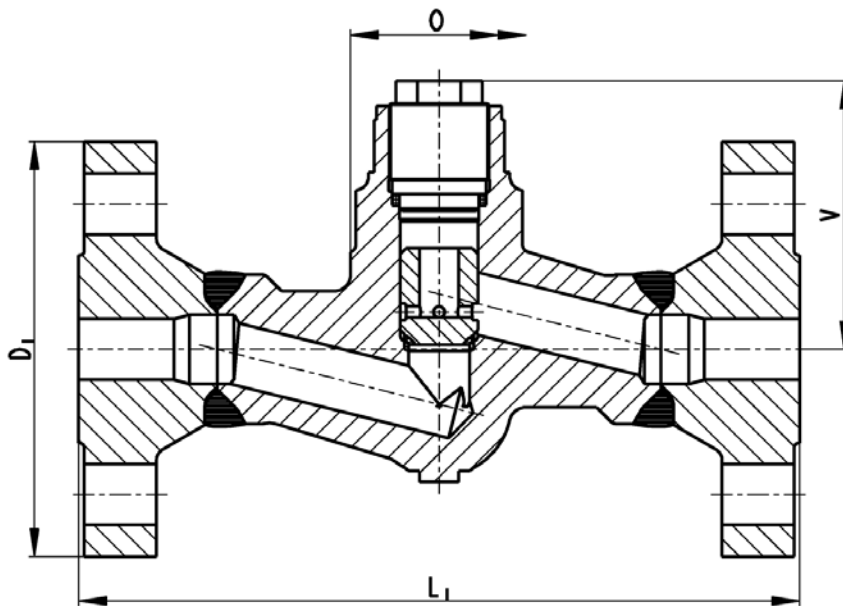

Butt-welded type, DN 10 – 100/80, PN 100 – 400

DN	PN	D mm	dp mm	L mm	O mm	H mm	V mm	m kg
10	100	14	10	150	54	34	77	2,1
	160		10					
	250		9					
	320		8					
	400		7					
15	100	22	17	150	54	34	77	2,1
	160		16					
	250		15					
	320		15					
	400	27	17					
20	100	27	23	160	54	48	98	3,1
	160	21						
	250	30	20					
	320		18					
	400		17					
25	100	35	28	160	54	48	98	3,1
	160		26					
	250		24					
	320		24					
	400	43	28					
32	100	43	36	210	78	66	128	7,2
	160		34					
	250		31					
	320		28					
	400		27					
40	100	49	41	210	78	66	128	7,2
	160		39					
	250		36					
	320		35					
	400	61	39					
50	100	61	52	250	94	83	145	11,4
	160		49					
	250	64	45					
	320		45					
	400		49					
65/50	100	77	66	250	94	83	145	11,4
	160		62					
	250		56					
	320		52					
	400		48					
80 100/80	100	*	*	*	*	*	*	*
	160		*					
	250		*					
	320		*					
	400		*					

Notes: Dimensions of butt-welded type are by ČSN 13 1075, in case of requirement of another standard (DIN, EN, ANSI) the dimensions could be different.

*) upon request

Flanged type, DN 10 – 100/80, PN 63 – 400

DN	PN	D ₁ mm	L ₁ mm	O mm	V mm	m kg
10	63-160	100	210	54	77	4,5
	250	125	230			6,6
	320	125	230			6,6
	400	125	230			7,4
15	63-160	105	210	54	77	4,7
	250	130	230			7,3
	320	130	230			7,3
	400	145	230			9,5
20	63-100	130	230	54	98	7,5
25	63-160	140	230	54	98	8,8
	250	150	260			10,7
	320	160	260			13,9
	400	180	260			18,4
32	63-100	155	260	78	128	13,9
40	63-100	170	260	78	128	15,6
	160	170	260			16,3
	250	185	300			20,9
	320	195	300			24,8
	400	220	300			35,7
50	63	180	230	94	145	21,1
	100	195	230			22,6
	160	195	230			24,8
	250	200	350			28,4
	320	210	350			33,4
	400	235	350			45,4
65/50	63	205	340	94	145	23,2
	100	220	340			25,7
	160	220	340			29,5
	250	230	400			37,6
	320	255	400			51
	400	290	400			75,2
80 100/80	63	*	*	*	*	*
	100	*	*			*
	160	*	*			*
	250	*	*			*
	320	*	*			*
	400	*	*			*

Notes: Dimensions of flanged type are by EN 1092-1, in case of requirement of another standard (DIN, EN, GOST) the dimensions could be different.

*) upon request

Advantages of construction

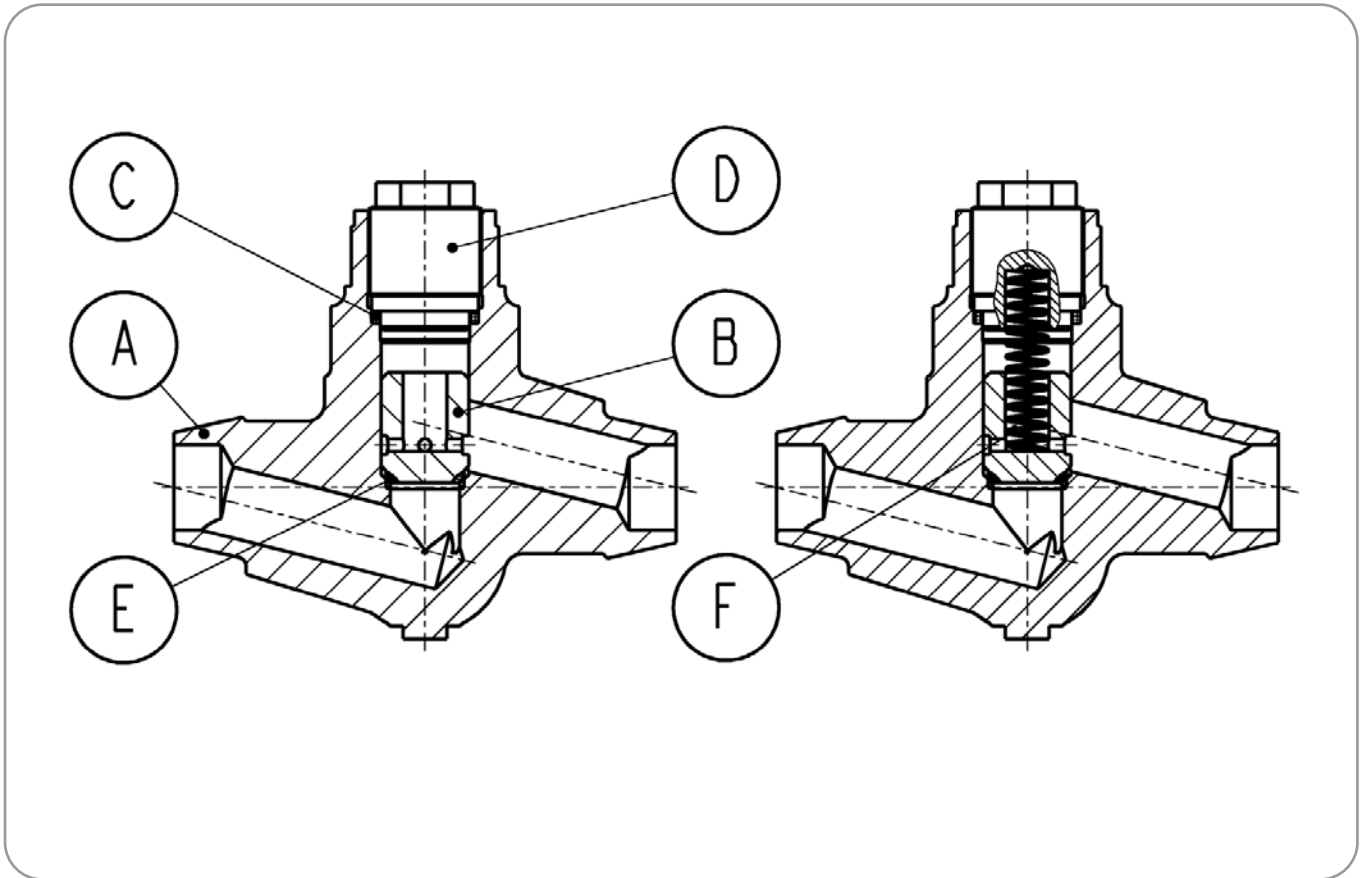

A	Decreased forged body without sealing weld: Decrease the weight, exclude the defectoscopy of weld
B	Plug maintain in body, with vents and grooves: Ensure the equalization of pressure and dehydration of space under plug
C	Sealing ring – expanded graphite: Reliable sealing, ecology
D	Screwing of body: Simple element, creates required sealing pressure
E	Seats are hardfaced (Stellite): Long-term life time, resistance against waring-ou
F	Spring: Push the plug to seat during position in inclined or vertical pipeline

MYYNTI / SALES:

**FINKOVA OY
SINIKELLONTIE 10 B
FI-01300 VANTAA**

TEL: +358 10 229 1570

EMAIL: finkova@finkova.fi

WWW: www.finkova.fi



HUOLTO / SERVICE:

**FINKOVA SERVICE OY
RAUDOITTAJANTIE 7 A
FI-06450 PORVOO**

TEL: +358 10 229 1570

EMAIL: info@finkovaservice.fi

WWW: www.finkovaservice.fi

